

Assembly Views and Component Labels

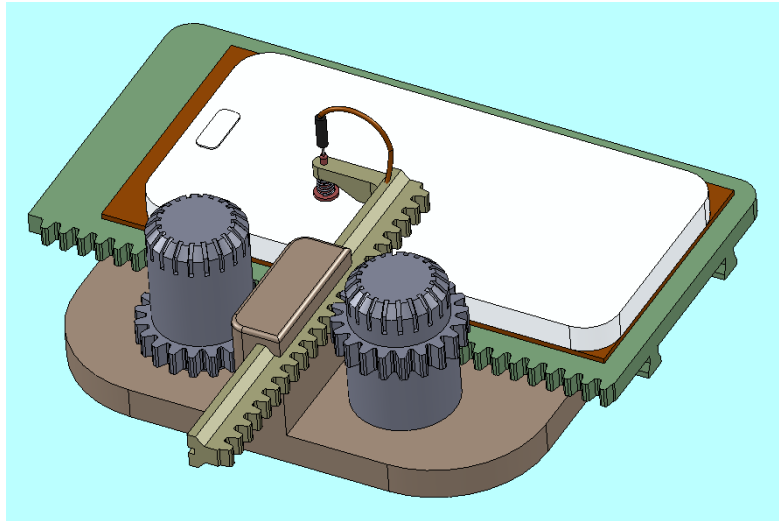

Iso View of Completed Assembly

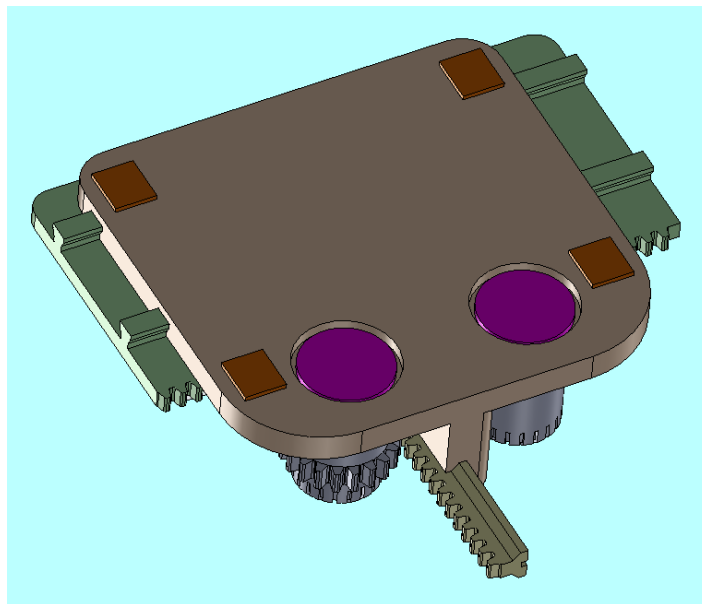

Bottom Iso View of Completed Assembly

* A list of purchased parts that are needed can be found in “Parts List- Cell Phone Sketcher.pdf”

** Operation of Cell Phone Sketcher is described in “Operation- Cell Phone Sketcher.pdf”

Exploded View and Component Labels

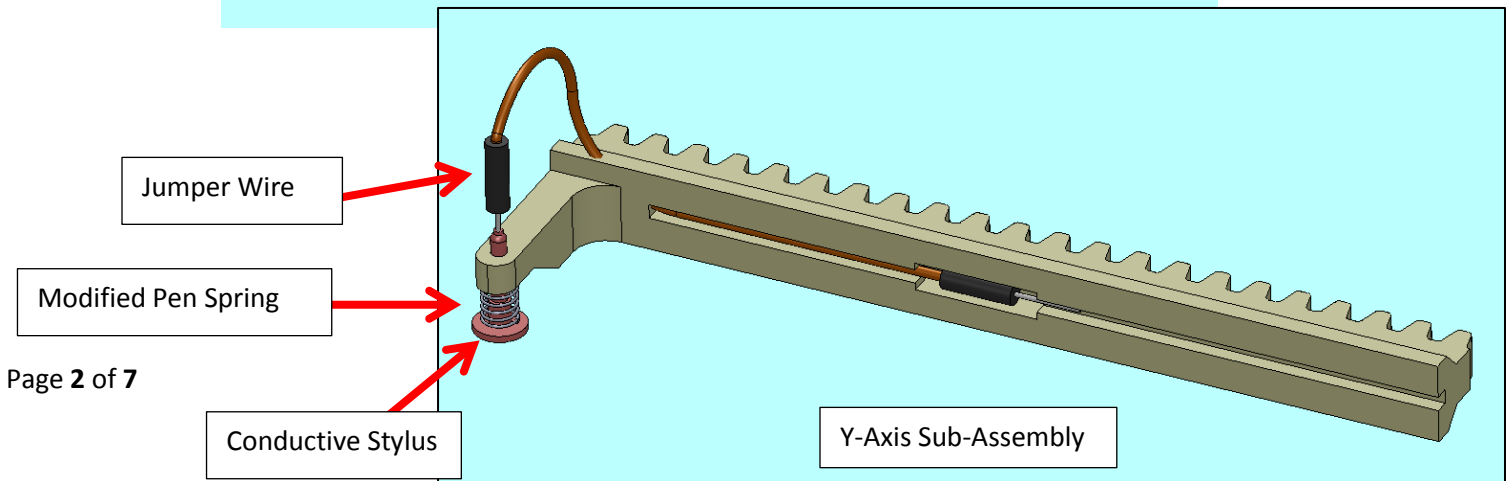
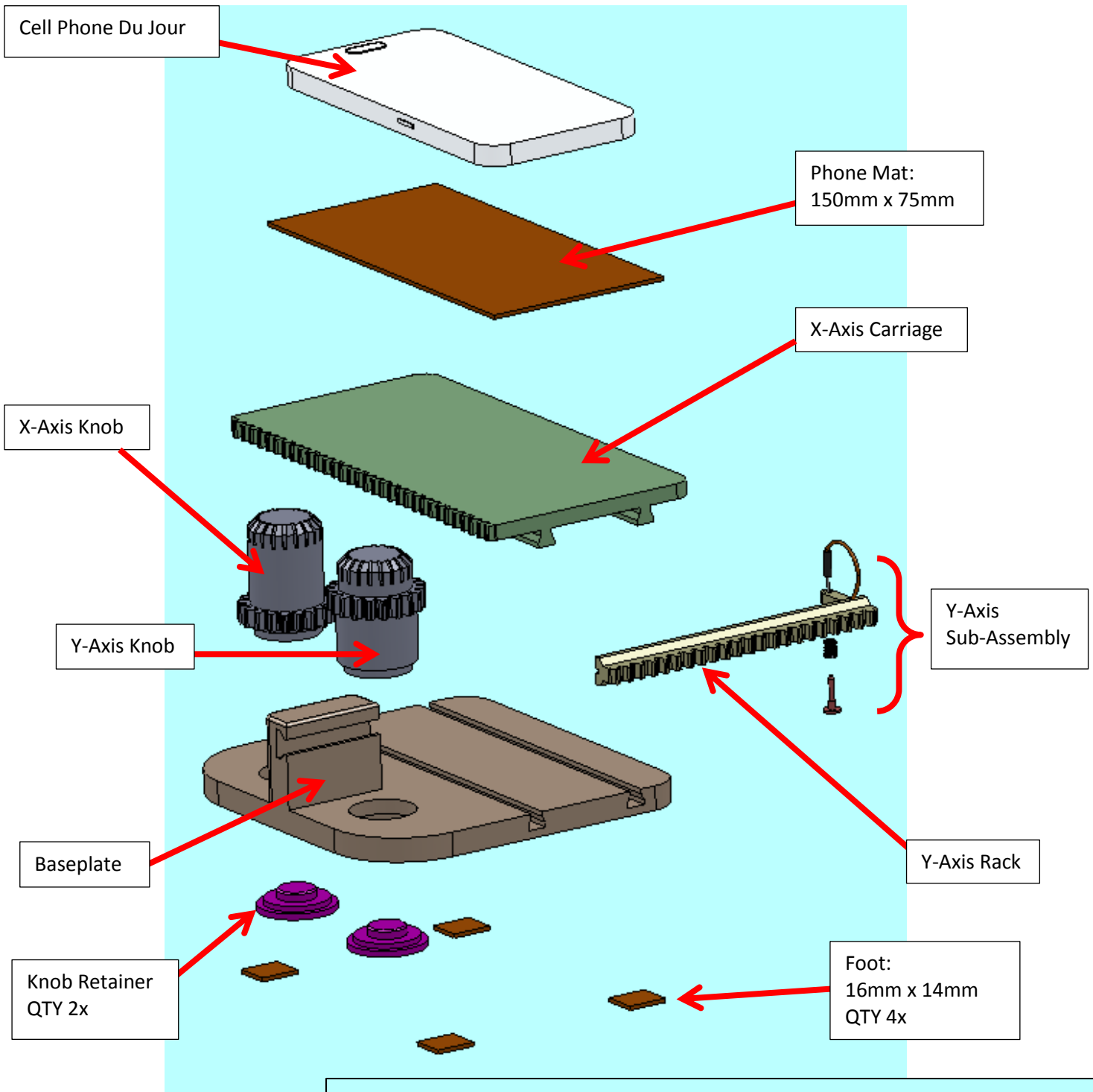

Assembly Instructions:

Print out the following quantities: [No scaling required]

- Baseplate, Cell Phone Sketcher [QTY 1x]
 - Print Settings used: PLA, 0.4mm layer height, 50% infill, Supports, Raft
 - Orientation= Largest flat surface down. Y axis pillar facing up.

- X-Axis Carriage, Cell Phone Sketcher [QTY 1x]
 - Print Settings used: PLA, 0.4mm layer height, 50% infill, Supports, Raft
 - Orientation= Largest flat surface down. Dovetail rails facing up.

- X-Axis Knob, Cell Phone Sketcher [QTY 1x]
 - Print Settings used: PLA, 0.4mm layer height, 50% infill, Supports, Raft
 - Orientation= Upright (circular features parallel to bed). Gear teeth as close to bed as possible.

- Y-Axis Knob, Cell Phone Sketcher [QTY 1x]
 - Print Settings used: PLA, 0.4mm layer height, 50% infill, Supports, Raft
 - Orientation= Upright (circular features parallel to bed). Gear teeth as FAR from bed as possible.

- Y-Axis Rack, Cell Phone Sketcher [QTY 1x]
 - Print Settings used: PLA, **0.2mm** layer height, 50% infill, Supports, Raft
 - Orientation= Long axis laying down, gear teeth printed in XY (not Z)

- Knob Retainer, Cell Phone Sketcher [QTY 2x]
 - Print Settings used: PLA, 0.4mm layer height, 50% infill, No Support needed, Raft
 - Orientation= Upright (circular features parallel to bed). "Steps" facing up.

During testing of different phone types, I found differences in the sensitivity of Apple devices vs Android devices, with regard to the phone sensing and responding to the Stylus. Please go to the appropriate section below, based on the type of cell phone you have.

Assembly for Android Cell Phones-

1. Ensure that the X-Axis slides smoothly in the dovetail grooves in the Baseplate. File, sand or deburr as needed.
2. Ensure that the Y-Axis slides smoothly in its mating dovetail groove. File, sand or deburr as needed.

- a. Use a 0.078in (5/64in) drill bit to clean up the hole in the Y-Axis that the Stylus fits through.
3. Ensure both Knobs turn freely and smoothly when set into the holes on the Baseplate. File, sand or deburr as needed.
4. Place the Knobs into the Baseplate and flip the assembly over. The assembly will be leaning at an angle, resting on the Knobs.
5. Use JB Kwik (epoxy) to bond the Knob Retainers to the Knobs. This will secure the Knobs in place. Ensure the Knobs can still spin smoothly after bonding.
6. Cut 4x Feet from the orange silicone sheet. These feet should be ~16mm x ~14mm.
7. Epoxy these Feet to the bottom of the Baseplate, in the 4 corners.
8. Flip the assembly back over.
9. Cut a Phone Mat from the silicone sheet. This should be ~ 150mm x ~75mm. Place this Mat on the X-Axis Carriage. Bonding the Mat to the X-Axis Carriage using epoxy is recommended.
10. Now we will assembly the Y-Axis Sub-Assembly:
 - a. **[**Be careful on this step and wear eye protection. Safety First!**]** Cut the ~22mm long pen spring in half, using heavy duty wire cutters
 - b. Place one half of the cut spring over the conductive stylus

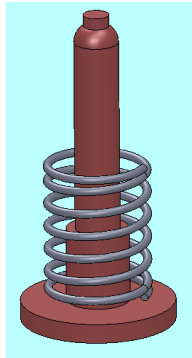

- c. Insert the stylus through the hole in the Y-Axis Rack, as shown below

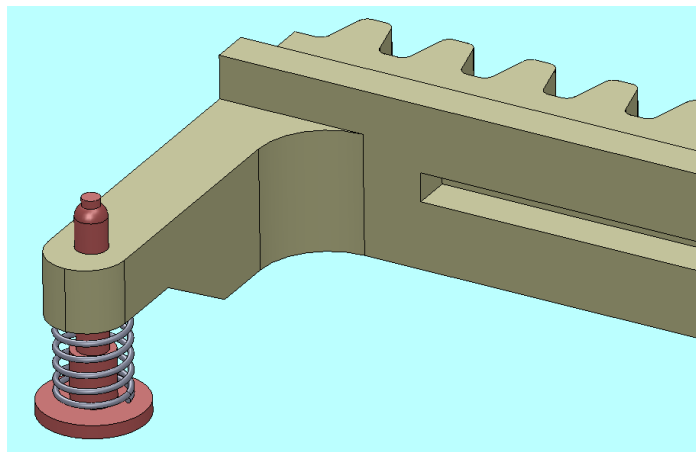

- d. Take the shortest size Jumper Wire (~120mm) and stick one end into the top of the Stylus, as shown below. This may take a little bit of force. The Jumper Wire does not need to penetrate the black material of the Stylus, it can be pushed in alongside it.

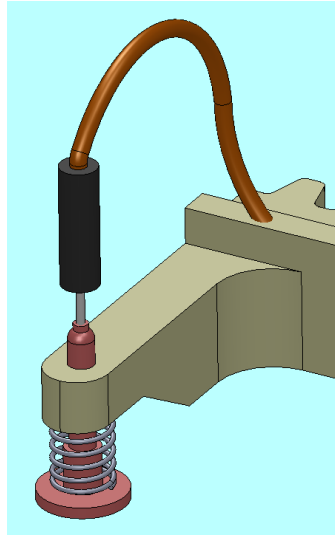

- e. Nest the free end of the Jumper Wire into the groove on the Y-Axis.

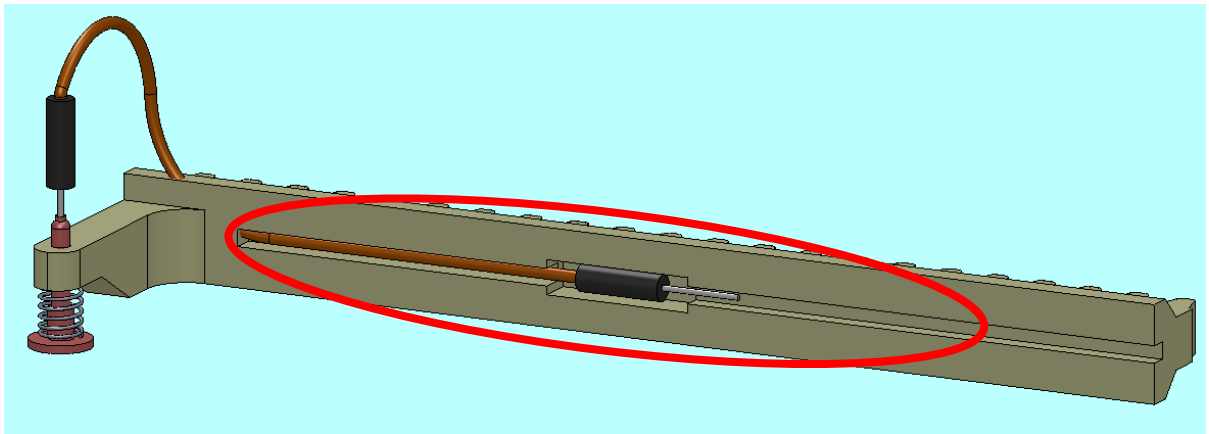

- f. Place epoxy on 2-3 locations, in the groove and over the Jumper Wire. Wipe away any excess epoxy, so that the Y-Axis Rack will still move smoothly through the dovetail groove. This epoxy will retain the Jumper Wire in the groove during operation. Let the epoxy cure.

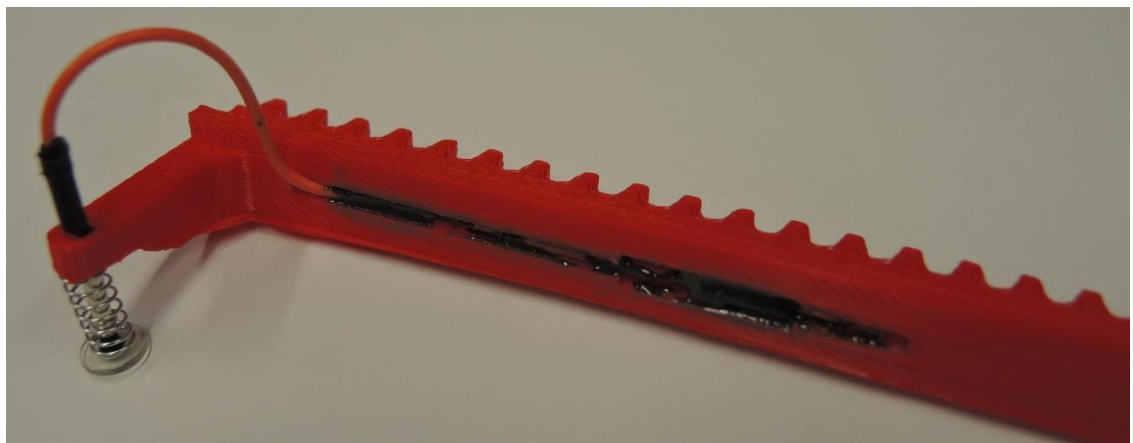

11. Insert the completed Y-Axis Sub-Assembly from step #10 into the mating dovetail groove on the Baseplate.

12. Your Cell Phone Sketcher is now ready to use! Please see the document “Operation- Cell Phone Sketcher.pdf”.

Assembly for Apple Cell Phones-

1. Follow steps 1-9 from the “Assembly for Android Cell Phones” section above.
2. Now we will assembly the Y-Axis Sub-Assembly:
 - a. Follow steps 10a-10c from the “Assembly for Android Cell Phones” section above.
 - b. Take the longest size Jumper Wire (~250mm) and stick one end into the top of the Stylus, as shown below. This may take a little bit of force. The Jumper Wire does not need to penetrate the black material of the Stylus, it can be pushed in alongside it.

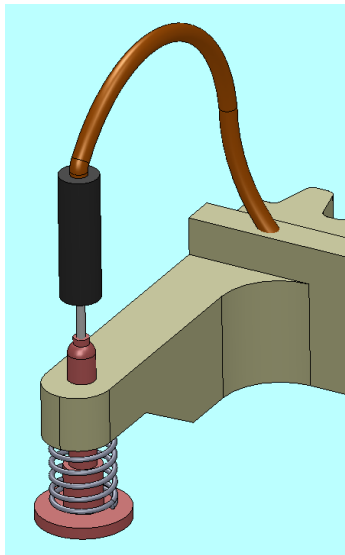

- c. Nest the free end of the Jumper Wire into the groove on the Y-Axis Rack. The Jumper Wire will extend out past the end of the Y-Axis Rack.



- d. Place epoxy on 3-4 locations, in the groove and over the Jumper Wire. Wipe away any excess epoxy, so that the Y-Axis Rack will still move smoothly through the dovetail groove. This epoxy will retain the Jumper Wire in the groove during operation. Let the epoxy cure.



3. Insert the completed Y-Axis Sub-Assembly from step #2 into the mating dovetail groove on the Baseplate.
4. Place the Wrist Strap Band over your bare wrist and use the attached alligator clip to clamp onto the metal part of the Jumper Wire sticking out of the end of the Y-Axis Rack. It is important that:
 - a. The metal plate on the Wrist Strap Band makes contact with the bare skin on your wrist.
 - b. The metal of the alligator clip clamps down on the metal needle-like end of the Jumper Wire.
5. Your Cell Phone Sketcher is now ready to use! Please see the document "Operation- Cell Phone Sketcher.pdf".

Safety Disclaimer:

There are some steps in this procedure that can be dangerous. Please use caution and wear the appropriate safety equipment. Potent Printables is not responsible or liable for injuries or damage caused by this procedure.