

E3Dv6 hotend mount by JB

[Picture]

Version 1.0	July 7th, 2014	Jonathan Bischof
Initial release		

Credits

This design is based on Nick Foley's „[E3D integrated printhead](#)“, published on Thingiverse.com.

Many thanks to Sanjay from E3D-Online for providing a free E3Dv6 hotend to make this design!

Table of contents

Credits.....	1
Design description.....	3
Features	3
Bill of materials	3
Printing instructions	4
Material.....	4
Print settings (Cura).....	4
Post-processing	5
Support removal.....	5
Ensuring a snug fit.....	6
Assembly instructions.....	7
Mounting the linear bearings.....	7
Mounting the hotend and fans.....	8
Hotend	8
Cooling fan.....	8
Putting everything together.....	9
Wiring & electronics.....	11

Design description

This is a mount for putting the E3Dv6 hotend (3mm Bowden version) into an Ultimaker 3D printer (UM original & UM2). It may fit other printers, as long as they use the same x-y gantry (6mm gantry shafts, with the Y-shaft 18mm higher than the X-shaft. See UM source files for details and bearings used.

My goal with this mount is to:

1. get solid, reliable performance
2. optimize size & weight for maximum movement speed & maximum build size
3. make it print reliably and without problems

This design re-uses Nick's cooling fanduct (see bill of materials).

Features

- Easy assembly with only two main parts (plus cooling fanduct)
- Strong construction using self-tapping screws
- Lightweight through slim and efficient design
- Aesthetically pleasing through clean and tidy layout
- Can be used with a traditional cooling fan, or in a crossflow fan setup by leaving the fanduct mount away

Bill of materials

- [E3Dv6 hotend, 3mm Bowden full kit](#)
- Printed fanduct from [Nick Foley's E3D-mount design](#) (preferably made of ABS, as this part is very close to the heater block!)
- 4x [self-tapping screws for thermoplastics](#), size 30x10 (3mm diameter, 10mm length)
Preferably with a large lens-head. Use a washer if the head has less than 6mm diameter ([alternate link](#)).
- 1x self-tapping screw for thermoplastics, size 30x12 (same type as above, but 12mm long).
- Cooling fan (50x10mm) plus mounting screws

Printing instructions

Every part of the hotend mount comes as a single STL file. The models are already oriented for optimal printing on a standard Original Ultimaker (cooling fan on the left side of the hotend, meaning “most difficult to print side of the model” on the left side). You may want to print all the parts together in “print all at once” mode for optimal cooling. Some parts are pretty small and can’t be printed alone.

Material

You need to print this mount from a material that can meet the following demands:

Temperature resistance: Even though the mount doesn’t come into direct contact with hot parts, it should resist high temperatures as good as possible. If you’re using a heated bed with an enclosed chamber, the air temperature around the hotend may rise above the usual ~ 45°C for PLA. You don’t want your hotend mount to soften up during a long print.

Stability: Select a strong material, especially concerning layer bonding. If you can break your parts apart by hand, you definitely need a better material.

Recommended materials:

(Please report your own recommendations in the [YM comment section](#))

- Colorfabb XT delivers excellent performance

Print settings (Cura)

These are the recommended settings for printing the hotend mount with Colorfabb XT.

All relevant settings are listed below. It is highly recommended to stick to them. Any settings not specified here aren’t considered relevant (leave them as you usually have them).

Greyed out settings are highly dependent on your printer setup. You may need to tune them.

Print all the parts with 100% infill in order to get them as strong as intended!

Basic tab:

Layer height: 0.1 mm

Shell thickness: 0.8 mm (2-pass with 0.4mm nozzle)

Fill density: 100% (!)

Print speed: 40 mm/s

Printing temperature: 255°C

Bed temperature: 62°C

Support type: None

Platform adhesion type: Brim

Advanced tab:

Nozzle size: 0.4mm (geometry, especially built-in support, is optimized for 0.4mm nozzles)

Post-processing

Careful post-processing is necessary in order to get a trouble-free assembly and operation. The parts are designed to fit very tightly, and do not allow for surface imperfections such as blobs or z-scars.

Recommendation: Use a sharp medical blade (scalpel) for post-processing. Take care not to cut yourself as these blades are extremely sharp. Never use much force for cutting, instead replace dull blades rather sooner than later.

Support removal

You will need to remove the built-in supports as follows:

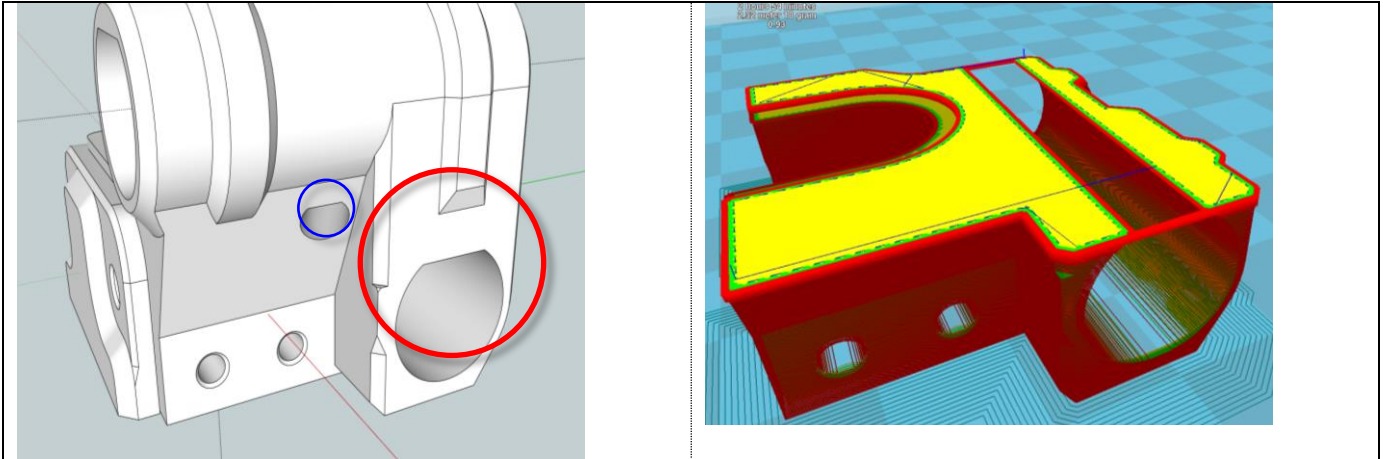

Bridging-helpers for the main linear-bearing tunnels (red circle). These supports help a lot with the bridging part, but need to be removed in order to get the bearings in. Remove all four supports (two on each tunnel).
One more bridging helper is located at the wiring-tunnel (blue circle).

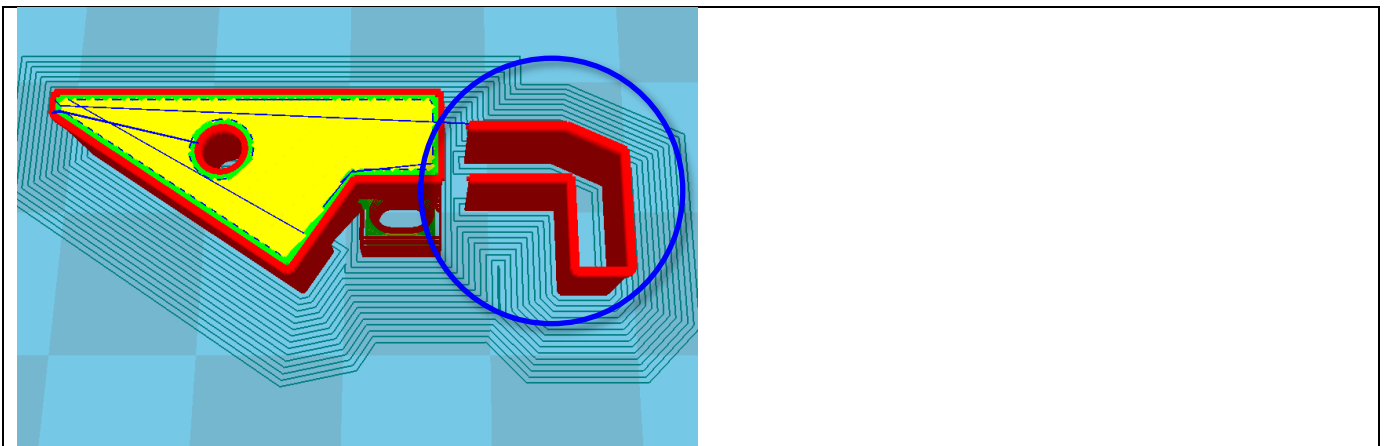

Support for fan-duct-mount. This should break off easily. Clean the surface after removing the support.

Ensuring a snug fit

Make sure all the parts fit together without leaving any gaps. You will need to carefully clean all surfaces that are adjacent to another part (remove any blobs, z-scar, bumps...).

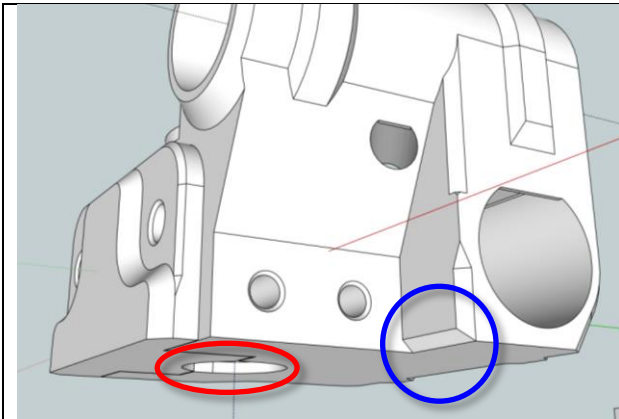

Make sure to cleanly remove the brim everywhere, especially on the edges that are marked in the picture to the left (blue and red circles).

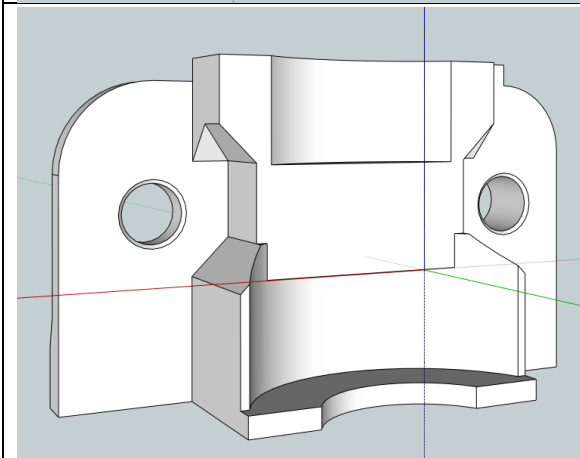

Pay special attention to the hotend clamp, as it is designed to fit to the main body part very tightly.

After that, make sure your hotend fits into the mount. If you attach the clamping bracket to fix the hotend in place, it should fit either just fine, or leaving a very small gap (0.5mm max). If there's a gap, make sure all the surfaces making contact with the hotend are very clean. You can close a very small gap when tightening the screws, but make sure you don't need too much force or you will damage the threads.

If you press the clamp against the main body, you shouldn't be able to rotate or move the hotend anymore. Take care not to bend the heat break when testing this!

This is the most critical part here, so make sure everything fits well!

Assembly instructions

Assembling the mount in the correct order will save you a lot of trouble. Please report any feedback to these instructions in the [YM comment section](#).

IMPORTANT:

Do not over tighten self-tapping screws! I have found a torque of 0.45 Nm to be optimal. This is not as much as you would tighten a screw that taps into a metal thread!

Using a torque-tool such as the excellent "[PB Swiss Tools MecaTorque](#)" (I'm using the 0.4-2.0 Nm bit-holder version) is an elegant solution to ensure proper tightening force.

Note that the thread of the 12mm long screw which holds the fanduct will be more fragile than the others, due to its printing orientation.

Mounting the linear bearings

Start with the linear bearings. You have already cleared the supports and cleaned the surface before. Now push the linear bearings into the tunnels.

This should be a press-fit. It may take considerable force to push the bearings in. Make sure that you push the bearings in 100% straight. You don't want to tilt / cant them.

Using a vise can be very helpful.

If you can't fit the bearings into the tunnels, please leave a [comment in the YM comment section](#). I will provide alternate versions with adjusted diameters if necessary. You can also try sanding the tunnels slightly if you don't want to re-print the part.

If the bearings are loose inside the tunnels, use some Kapton tape to increase their diameter before you push them into the tunnels. This shouldn't happen with the current version. If it does, you probably have some deformation problems.

Make sure you don't split the part when pushing in the bearings!

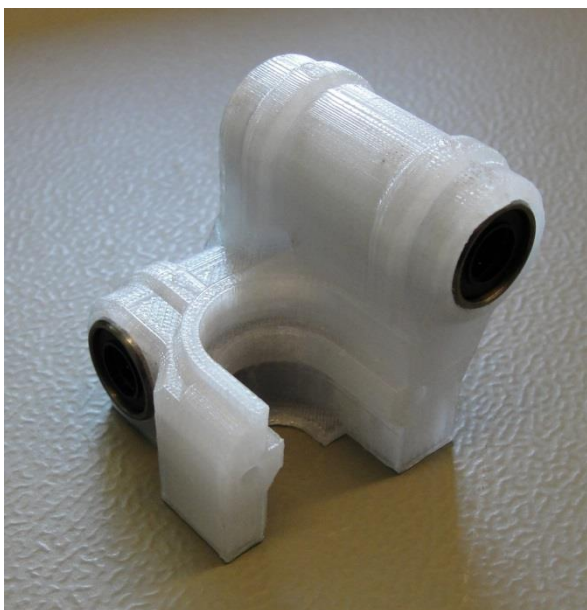

Mounting the hotend and fans

Hotend

Assemble the hotend according to the [E3D assembly guide](#), BUT:

- Make sure you put the blue fan duct on with the canted side facing downwards (to the nozzle). Also, attach the small fan with the wires facing upwards
- When handling the hotend, always watch out that you don't bend the heat break!

Cooling fan

Attach the cooling fan to Nick's fan duct. Orientate it so that the wires come out close to the mounting socket.

Make sure the mounting screws don't protrude from their threads:



You may need some washers, or have to shorten the screw in order to get the right length.

Attach the fan duct to the fan duct mount using the 30x12 self-tapping screw.

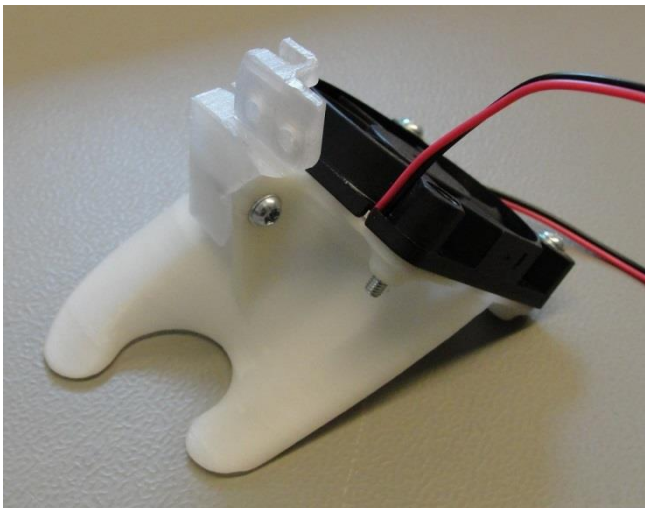

Putting everything together

Attach the fanduct mount to the main body using two 30x10 self-tapping screws, but don't tighten the screws yet. You need them to leave some space for the wire guides to remain opened:



Now, guide the wires of both fans through the wire guides, and through the tunnel and towards the center of the mount:

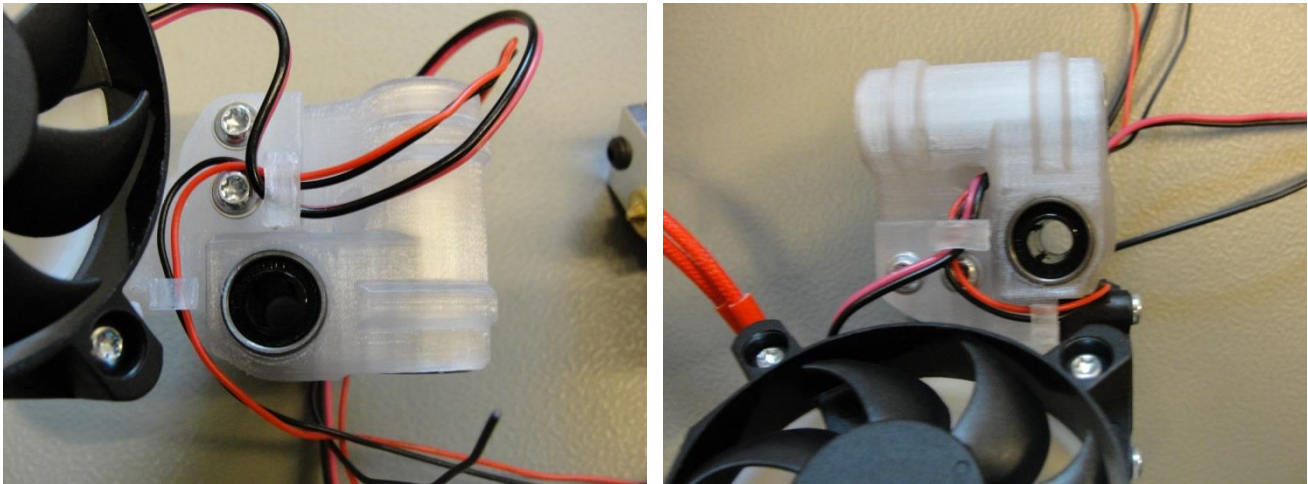

After that, tighten the two screws to fix the fanduct mount and secure the wires in their guides.

Next, put the hotend into the mount's socket, and put on the hotend clamp. Use the remaining two 30x10 self-tapping screws to hold the hotend clamp to the main body, but don't tighten the screws yet! You need to be able to rotate the hotend:

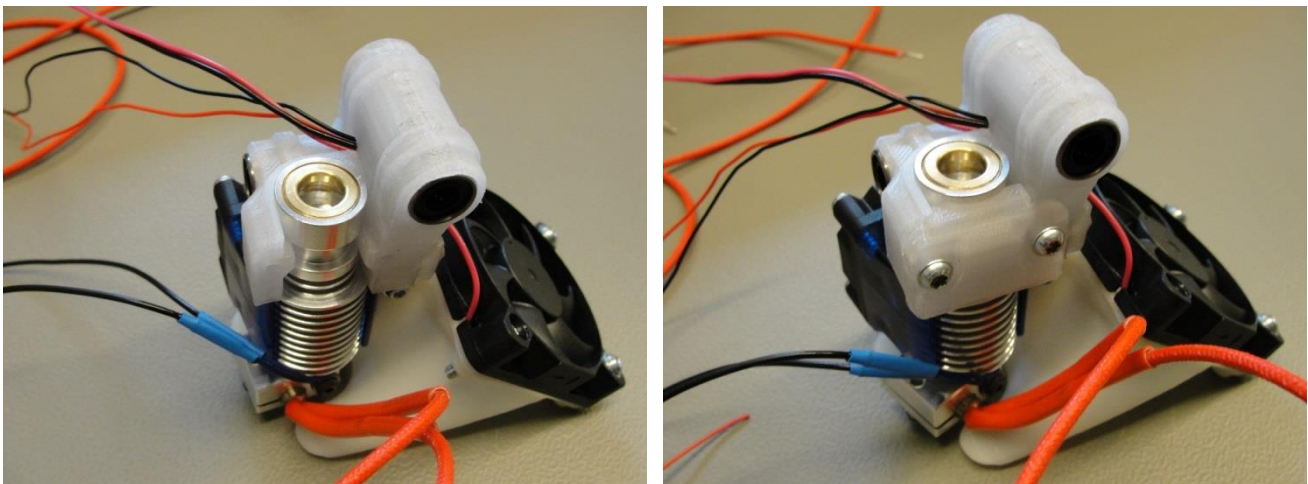

Rotate the hotend so that the heater block keeps a good clearance to the cooling fan duct:



Now you can tighten the screws holding the hotend clamp.

The hotend must not be able to rotate or move anymore.

That's it; you've completed the hotend assembly!

Wiring & electronics

Work in progress...